

MATERIAL LIST:

- 1 Step link body
- 1 Bushing
- 1 Clevis pin and ring
- 1 Length of 1/16" line
- 1 Bolt with lock nut

INSTALLATION:

Hobie 14 (older models without mast step links).

1. Drill a 1/4" hole in the mast base as shown in **figure A**.

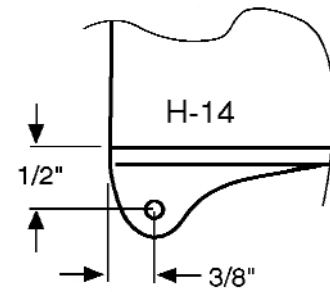

Fig. A

Hobie 16 (older models with molded aluminum hook system).

1. Drill a 1/4" hole as shown in **figure B**.
2. Remove hook by filing, leaving at least 3/16" of material around hole.
3. Drill head off press pin in mast step casting and remove with punch and hammer.

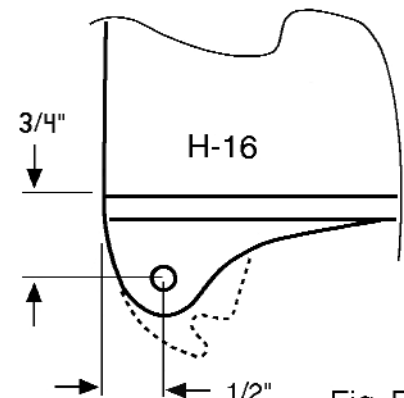

Fig. B

14 & 16:

1. Place bushing into narrow end of link.
2. Install link in mast step casting as shown in **figure C**. (There is an "up" arrow stamped into the left side of the link).
3. Tie line around bushing then to ring installed in clevis pin. This will hold pin captive.

NOTE: Link must fall clear of mast base when not in use.

USE:

1. Pin link to mast base using appropriate hole (hole marked 14 or 16).
2. Check above for power line or overhead wires!!!! Contact of mast with overhead wires could be fatal!!!
3. On level ground, face boat into wind or away from the wind. Avoid stepping mast in cross wind.
4. Stand on the rear crossbar and raise the mast to your shoulder. At this time check to be sure that shrouds and trap wires are clear of the rudders and corner castings.
5. If all is clear. Walk forward and raise the mast as you go. Once in the full upright position the mast will lean on the shrouds and the forestay can be attached to the forestay adjuster.
6. Before raising the sails be sure to remove the step pin which allows the link to fall to the down position. This will allow the mast to rotate.

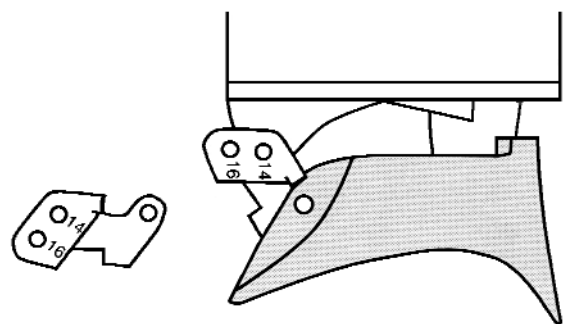

Fig. C