

HOBIE MIRAGE

SPORT



OWNER'S MANUAL





Welcome to the Hobie way of life.

Thank you for choosing a Hobie Mirage Kayak. As a member of the Hobie way of life, you are now on the road to pure adventure in pedaling and paddling. This owner's manual is designed to help you get maximum enjoyment from your new Hobie kayak. But more important, it is designed to help you use it safely.

TABLE OF CONTENTS

	<u>PAGE</u>
Welcome.....	1
Unique Hobie Mirage Sport Features.....	2
Rudder Installation and Adjustments.....	3
Mirage Drive Installation and Maintenance.....	4
Mirage Drive Diagram	4
Basic Kayak Features.....	5
Safety/Righting Techniques	5
How to Pedal and Paddle	6
How to Store/Transport your Hobie Kayak.....	7
Recommended Equipment	7
About Polyethylene.....	7
Frequently Asked Questions "FAQ"	7
Warranty	8
Hobie Cat Company Contact Information.....	8

HOBIE MIRAGE SPORT

FEATURES

STORAGE

6" hatch to access a removable "goodie bag" and more space

OPTIONAL SAIL RIG

Scupper hole functions as a sail rig mount.

VERSATILE

Pedal or paddle. Multiple foot positions fit virtually all paddlers comfortably.

DUAL PADDLE STORAGE

A paddle can be conveniently stored on either side of cockpit.

DRINK HOLDERS

One on each side of cockpit

HAND STEERING

Simply point toward direction you want to go.

SIT-ON-TOP DESIGN

The Hobie Sport's open-top cockpit allows the user to enter and exit the kayak easily from the shore, dock or water. Scupper holes make the kayak self-bailing. The design also eliminates the need to perform an Eskimo roll (advanced kayak technique). The contoured seat is fitted with an adjustable backrest for added comfort. The multiple footwells allow you to adjust your leg position when paddling and not using the pedal system.

HULL DESIGN

The long center "keel" area encourages the kayak to track straight when paddling and coasting. Under moderate paddling conditions, the wider "shoulder" area of the hull rides high at the surface of the water without compromising speed. If the kayak is fully loaded with gear or is being paddled and braced in rough conditions, the "shoulder" areas provide secondary buoyancy and stability.

HANDLE AND ANCHOR LINE GUIDE

DRY

Closed deck and raised coaming help keep water out of cockpit.

SELF-DRAINING COCKPIT

Scupper drains water from cockpit.

HOBIE MIRAGE DRIVE

This unique propulsion system is patented by Hobie. The Hobie Mirage Drive efficiently converts a simple fore-and-aft pedal motion into forward speed. Adjustable pedal positions make pedaling the Mirage comfortable.

KICK-UP-RUDDER

Flip lever to raise rudder for beaching or shallow water

INTERNAL STORAGE ACCESS

Large internal hatch for storage within hull.

SMALL ITEM "TRAYS"

Small tools, hooks, lures, flies and other small items are easily accessible in the recessed trays that surround the cockpit.

CARRYING HANDLE

A padded carrying handle makes it easy and comfortable to carry your kayak around or put it on your roof rack.

ADJUSTABILITY

A second set of under-seat plugs allows the seat to be moved forward to accommodate for the smallest of kayakers.

COMFORTABLE

Seat is ergonomically designed to reduce fatigue and pressure points while pedaling. Positioned higher than footwells, the seat is dry and comfortable. An under-seat drain plug allows for a dry ride even when the boat is laden with lots of gear.

GRAPHICS

Molded-in graphics won't peel or flake off during the life of your kayak.

LARGE EXTERNAL STORAGE AREA

Spacious pick-up style storage area holds all sorts of gear...a tackle box, dive tank -even the family dog.

HANDLE

RUDDER

Custom balanced elliptic shape for effortless turning

ASSEMBLY INSTRUCTIONS

INSTALLING THE RUDDER

After the packaging is carefully removed, follow these simple steps...

- 1) Remove one of the two keeper rings (A) from the plastic pin (B) that is installed in the stern (rear) of the kayak.

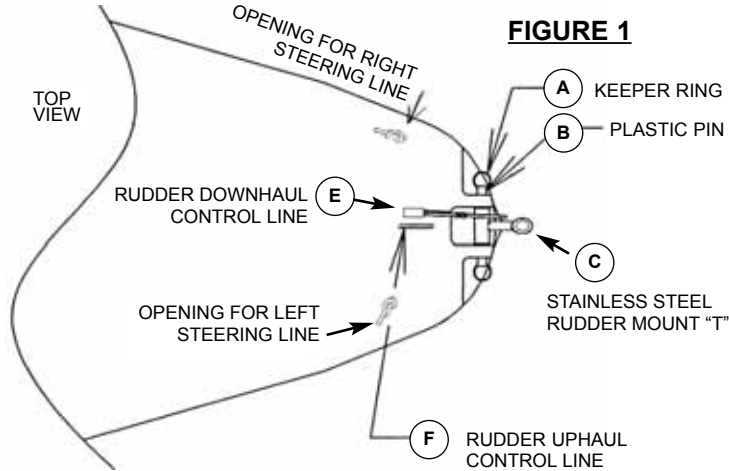

- 2) Slide the pin partially out of the hull.

- 3) Detach the stainless steel rudder mount "T" (C) from its shipping position (which is taped on the side of the kayak underneath the shelf of the boat) and align the top of the "T" with the holes from where the plastic pin was removed. The shaft (D) points downward. Be sure to run the rudder downhaul line (E) over the top of the "T" fitting as shown. Reinsert the plastic pin through the hull and the stainless steel rudder mount "T". Replace the keeper ring.

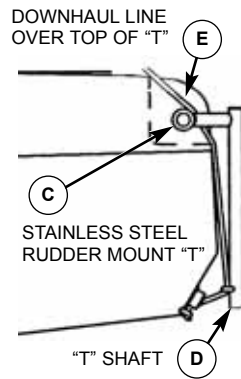

- 4) Locate the rudder (G). Align the rudder over "T" shaft (D) as shown at right.

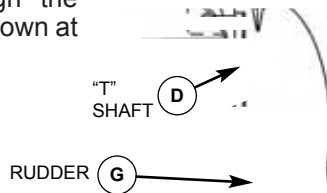

- 5) See **FIGURE 2** Place the rudder kick-up control handle in the rudder-up or handle-forward position. While the rudder "T" shaft (D) is in a mostly up position (Note: Figure 2 shows the rudder in the down position), insert the stainless steel rudder pin (H) (taped to the deck near the stern) through the rudder (G) and "T" shaft (D) and turn the stainless steel rudder pin clockwise until snug. Be sure that it is fully threaded into the rudder. **DO NOT OVERTIGHTEN.**

FIGURE 2

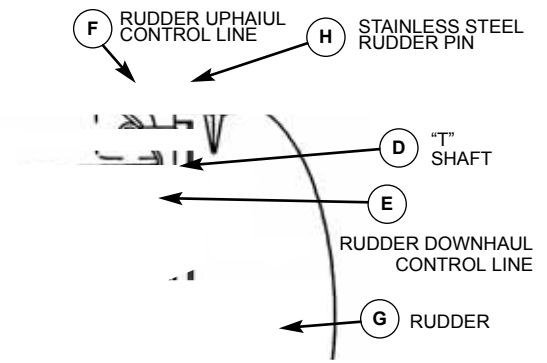

- 6) **SEE FIGURE 3** With the rudder locked in the down position, feed each steering line up through the outermost holes in the rudder (I & J), under washer and around screw (K) in a clockwise direction. With the rudder and the steering handle straight, pull all the slack from line and tighten the screw. Do the same for both sides. The extra line can be cut or tucked under itself.

FIGURE 3

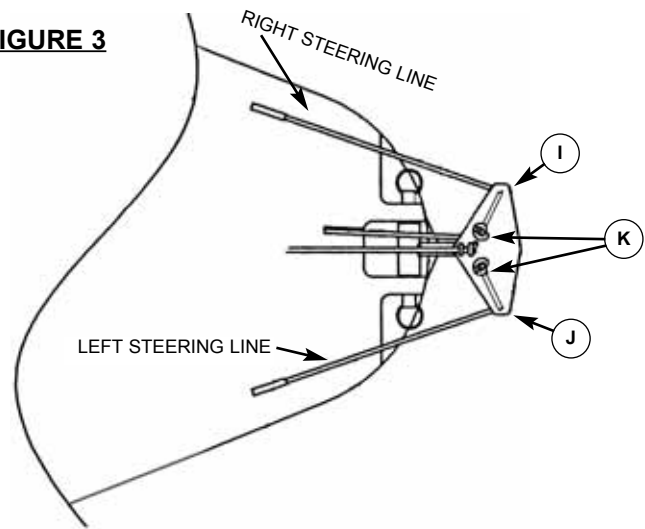

CONTROL LINE TENSION

RUDDER STEERING LINES

It is desirable to have some friction in the steering system so the rudder does not move from side to side excessively when you remove your hand from the handle. The amount of friction can be a personal preference and can be adjusted by changing the tension in the steering lines. More tension equals more friction and vice versa. Re-tension the steering control lines to increase rudder friction.

Note: It is normal for one of the steering lines to go slack in a hard turn, and for both steering lines to go slack when the rudder is up.

STORING THE RUDDER

The rudder can be removed for storing or transporting. To remove (see **FIGURE 2** and **3**), unfasten the steering control lines from the top of the rudder. Tie a stop knot in the line so it doesn't accidentally get pulled into the boat. Turn the rudder pin counter-clockwise while the rudder is half-way up. Pull the pin out to separate the rudder from the "T" shaft. Place the rudder pin into the "T" shaft.

MIRAGE DRIVE

INSTALLATION

- 1) Insert Hobie Mirage Drive into the opening of the hull near the footwells so it is facing forward. The front of the Mirage Drive can be determined by the location of the sail masts (See **FIGURE 5**). The forward side is to the left in the diagram.
- 2) Turn locking knobs on both sides of the Mirage Drive until snug.



UNLOCKED



LOCKED

ADJUST PEDALS

To adjust the pedal position, (1) squeeze the handle, (2) move the pedal and release the handle. Make sure the pin drops into the new hole.

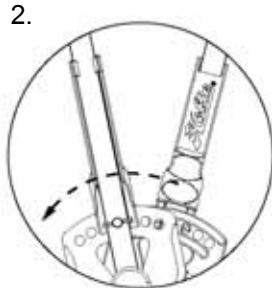
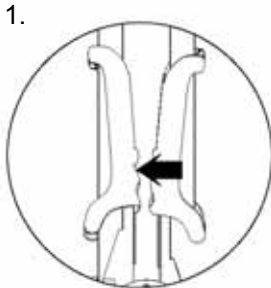

WASHING

After using in salt water or dirty water, wash the Mirage Drive with fresh water. Allow to dry, then spray metal parts with WD-40™ or equivalent. Special attention should be paid to threaded cable ends, lock nuts, chain, shafts, pedals, and adjustment pins.

CABLE ADJUSTMENTS

Determining if adjustment is needed...

Occasionally the cables may need to be re-tightened. The cables should be kept taut; however, the front chain should be a little tighter than the rear chain. Push with thumbs at the points marked (L) with moderate pressure (see **FIGURE 6**). The side of the chain should not go beyond the inside edge of the drum casting.

FIGURE 5
SIDE VIEW

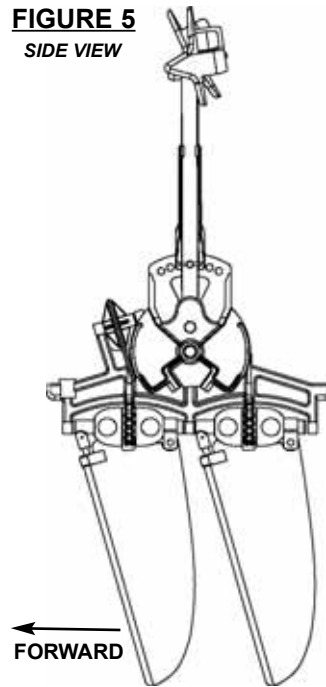
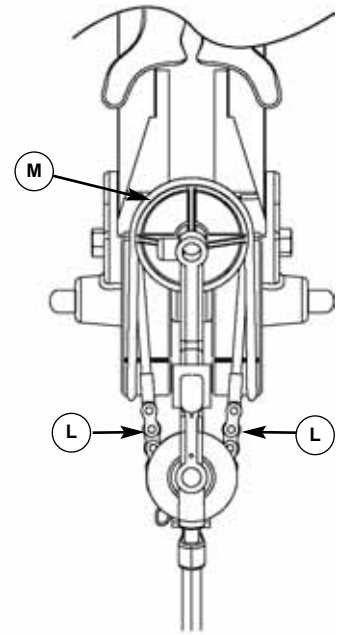

FIGURE 6



DRUM CASTING

When turning cable adjusting nuts, use a vise grip on the solid portion of the stud to prevent the cable from twisting. Turn the nut with a 7/16 inch open-end wrench, only giving it one half a turn at a time, then do the same to the remaining three nuts. Re-check the tension and adjust accordingly.

Note: Keep the pedal shafts and masts parallel. When the shafts are together, both masts must be straight down. The idler pulley cable (M) will be tightened automatically when the front chain assembly is tightened.

MISCELLANEOUS MAINTENANCE

Periodically check for loose screws, cotter pins or frayed cables. If a cable has a broken strand, replace it with new cable.

CAUTION

Care should be taken to avoid hitting objects with the Mirage Drives. If you bend a mast, it usually can be straightened. To straighten a mast, remove the Mirage Drive from the boat and insert the drive into something solid, such as a vise. Remove the sail, then carefully bend the mast until straight. To test for true, roll mast on a flat surface and straighten as needed until the masts roll evenly. If the mast cannot be straightened or becomes cracked or fatigued, replace the mast.

BASIC KAYAK FEATURES

The front of the boat is the “bow” and the rear is the “stern”. When looking forward to the bow, the left side of the boat is “port” and the right side is “starboard”. The hull ID number can be found on the bottom of the boat, at the stern.

In the middle of the boat, there is a cockpit area, with the seat (toward the stern) and footwells (toward the bow). Inside the cockpit are scupper hole(s) that go all the way through the boat. These scuppers allow the boat to drain. Your particular model may have hatches that allow access to the inside of the boat for gear storage.

Alongside the cockpit are a series of small “U” straps, called pad eyes. These are used to attach accessories such as backrests.

All Hobie kayaks are made of linear polyethylene, making them repairable and recyclable.

SAFETY

Paddle/pedal sports can be dangerous and physically demanding. The user of this product should understand that participating in kayaking may involve serious injury or death. Observe the following safety standards when using this product. These are basic safety rules that all boaters should follow. Always use common sense and follow all safety rules at all times.

- To avoid damage to the Mirage Drive, push either pedal completely forward before beaching or in shallow water. Use small, partial, pedal strokes with one pedal nearly all the way forward until there is adequate water depth for the Mirage Drive to have complete clearance in the water.
- Consult your physician prior to beginning paddle/pedal sports.
- Carry a spare paddle.
- Obtain paddle/pedal sports instructions from your dealer specific to this type of craft.
- Obtain certified first aid training and carry first aid and rescue/safety equipment.
- Always wear a nationally Coast Guard approved personal flotation device.
- Wear a helmet where appropriate.
- Dress appropriately for weather conditions; cold water and/or weather can result in hypothermia.
- Check your equipment prior to each use for signs of wear or failure.
- Never pedal or paddle alone.
- Always tie a leash to your paddle.
- Do not pedal or paddle in flood conditions.
- Be aware of appropriate river water levels, tidal changes, dangerous currents, obstacles in and above the water and weather changes.
- Scout unfamiliar waters; portage where appropriate.

- Do not exceed your paddling/pedaling ability; be aware of your limitations.
- DO NOT use alcohol or mind-altering drugs prior to or while using this product.
- Follow the manufacturer’s recommendations for use of this product.
- If additional outfitting is added to this craft, use manufacturer-approved materials only; do not impair entry or exit access.
- Read owner’s information package prior to using this product.

The user of this product acknowledges both an understanding and assumption of the risk involved in paddle/pedal sports.

Beware of offshore winds that may make it difficult to return to shore.

When paddling in a new area, check with the locals regarding currents, shoreline conditions and weather patterns. Plan an “escape route” -- an alternative place to get off the water should environmental conditions dictate.

Hobie Kayaks were not designed for fast moving water.

HOW TO PERFORM A SELF RESCUE

If you fall out of your boat, don’t panic. Stay with the boat. You should be wearing a life jacket which will keep you afloat. There are many ways to get back up on the boat.

If the boat is upside-down, it will need to be turned over. To do this, reach across the bottom of the boat and grab the scupper hole or Mirage Drive and pull the boat upright.

Position yourself so your head is near the cockpit area of the boat and you are facing the boat. You will want to be between the seat and the footwell areas of the boat.

Reach across the boat to the far edge with one hand. Place the other hand on the near-side rail, then kick with your feet, pulling yourself up and onto the boat, so your belly is across the center line of the boat. (Your belly should end up between the footwells and the seat.)

Next, roll over onto your backside toward the seat, which should place your backside in the seat. Sit up, swing your feet into the footwells and you’re ready to go.

The key to this method is to keep your center of gravity low and near the centerline of the boat. Your body and head should stay close to the boat.

CAUTION: While righting the Hobie Mirage or climbing back aboard, stay clear of the pedals, pedal shafts, sails and adjustment straps. Avoid being hit by them or getting them hooked on your life jacket.



PEDALING

First adjust the pedals as shown on page 4. Adjustments can be made for a variety of leg lengths. Adjust the pedal positions equally. Sit with one pedal all the way forward so your knee stays slightly bent when your leg is fully extended. Then you simply pedal back and forth to propel the boat forward. For pedaling in shallow water, partial strokes with one pedal forward and one aft allow for retraction of the sails in shallow water. When there is adequate water for clearance of the fins, full strokes can be used. For additional speed you can paddle as well as pedal.



Before beaching or launching, push one pedal completely forward to retract the Mirage Drive fins up against the hull and kick up the rudder by flipping the lever on the right side of the boat to the forward (rudder up) position. To take off from the beach, push out to deeper water or paddle out before putting the rudder down and pedaling the Mirage Drive.

If launching from a rocky or wavy shore, to avoid damage to you Mirage Drive, paddle into deeper water before installing it (Be sure to tether the Mirage Drive to you kayak when it is not installed.) You may also prefer to remove the Drive before beaching.

PADDLING

You can choose to paddle, pedal or combine the two. These guidelines will help you to get started.

To start, sit in your kayak. Your backside should be all the way back in the seat and your knees comfortably bent. To find the proper footwell, straighten your legs all the way out and then bring them back one "well". If your legs are too outstretched, you may experience strain on your lower back. If your knees are bent too much, you may end up knocking your kneecaps while paddling.

For proper hand placement on your paddle, start with your hands about a shoulder's width apart and centered. If you place the center of the paddle on top of your head, your elbows should form slightly less than a 90 degree angle. There should be an equal amount of paddle shaft beyond each of your hands.

Some paddles may have the blades offset, or "feathered", at some degree from parallel. A feathered paddle presents less surface area for the wind to catch as that blade moves forward through the air. Some paddles have a flattened spot along the paddle shaft that will help keep your "control" hand in a fixed position. However, a special technique must be used to get each blade in the water. If the paddle is right-hand controlled (when the right blade is held vertical, the left blade "scoop" is pointed mostly up), the right hand will stay tight and the left hand loose. To learn the process, hold the paddle tight in your right hand and loose in your left. Using the right hand, rotate the paddle blade back and forth; it should spin in your left hand. Now take a stroke on your right, then cock your right wrist back (left hand staying loose and somewhat open) and take a stroke on your left. If using a left-hand control paddle, reverse the process. The left hand stays tight and the right hand loose.

The basic paddle stroke will give you forward power. Place a paddle blade in the water near your toes. Pull the paddle blade back alongside the boat to approximately your hip area while your opposite hand and paddle blade move forward. Then lift the first paddle blade out of the water while lowering the second blade into the water and take a stroke with the other side.

If you pull the paddle out and away from the hull in an arc, it will force the bow of the boat to swing away from the paddle blade. This is called a "sweep stroke" and is used to turn the boat.

MORE PADDLING TIPS

Hobie kayaks are very easy to use and very forgiving. By beginning in calm water, you can quickly get the feel of the boat and paddle techniques. Practice getting in and out of the boat by yourself.



Relax your hands when paddling; a tight grip is not necessary!

Sit with good posture while keeping your torso vertical. Choose a footrest position that will allow your knees to be slightly bent.

For greater efficiency use not only your arms, but your torso and shoulders as well. Start out easy until you get the feel of the paddle and the steering strokes. Most experienced paddlers use an offset (feathered) paddle, but beginners may prefer to keep the paddle blades square.



STORING YOUR HOBIE KAYAK

Hobie has chosen a blend of plastic that has an added measure of ultraviolet inhibitors to provide superior protection from ultraviolet light. However, to ensure extra years of flexibility and bright colors, avoid storing the boat exposed to weather or in direct sunlight.

Kayaks should be stored on edge, upside down on the cockpit rails, standing on end or hanging on its edges. When hanging your kayak upside-down, run straps around the boat near the cockpit. A word of caution: hanging by the scupper hole(s) may cause distortion, and hanging from the handles may place undue strain on them. Storing the boat bottom-side down may also cause distortion. Kayak storage systems are available from your dealer. Padeyes are NOT intended for hanging or for use as tie-downs.

To secure your kayak, simply run a cable through a scupper hole and lock it to something secure.

TRANSPORTING YOUR HOBIE KAYAK

The easiest ways to transport your Hobie kayak is to purchase a roof rack from your dealer. This normally involves a set of crossbars that attach to the car via the rain gutters or adapter clips mounted to the door frame. They come with a wide variety of attachments from kayak saddles to stackers. The racks can be used without the attachments but the racks should be padded. To help prevent distortion, place the kayak, cockpit side down, on top of the rack. It is best if the crossbars contact the cockpit sides and not the deck areas. Straps can then be laid across the boat and tied to the bars. Saddles cradle the boat and often come with their own straps. Stackers allow multiple boats to be placed on their sides without falling over.

An alternative to traditional rack systems are soft racks. They tend to be less expensive and will work with most cars. These are pads mounted on straps that sit between the kayak and the roof of your car. Some styles have a strap that wraps around the kayak and others strap the pad to the roof. To tie the boat to the car, straps are run through the car doors and the boat is tied to the roof as well as the bumpers, front and rear. Over-tightening the straps may cause dents in the roof of the car. Be sure to first consult your owner's manual for the car and roof rack system to ensure that you comply with all of their recommendations, precautions and specifications.

A line run from the bow and stern of the boat to each bumper is required. If your bumpers do not have a gap to pass a rope around, look underneath. There should be a loop of metal, which is used by car transports such as tow trucks.

Many people like to use the scupper holes to tie the boat to the car. This helps prevent the boat from sliding back and forth or the tie-down rope from slipping off the kayak. This is a perfectly acceptable method for tying the boat down.

RECOMMENDED EQUIPMENT FOR SPECIFIC TYPES OF PEDALING AND PADDLING

Basic Boating: Life Jacket, Paddle, Paddle Leash, Backrest, Safety Whistle, Filled Water Bottle, Appropriate Safety Equipment.

Longer Distance Touring: Dry Bags, Chart, Compass.

Additional Equipment for Diving: Dive Flag, Anchor.

Fishing: Fishing Rod Holder, Drip Guards, Gear Bags, Knee Braces.

ABOUT POLYETHYLENE

Continuing Hobie's tradition of offering the latest in technology at an affordable price, your new kayak is made of rotomolded super linear polyethylene. Polyethylene offers a major advantage because it is virtually indestructible under normal use. Being somewhat flexible, it gives on impact and derives its stiffness from compound curves. Polyethylene is very abrasion-resistant.

FREQUENTLY ASKED QUESTIONS (FAQ)

How watertight is my boat?

It is normal for any type of kayak to experience a small amount of seepage due to the installation of rivets, hatches, etc. Kayaks may take on a few cups of water while out paddling. If your kayak is taking on more than that, check to make sure the drain plug is in, then check the rest of the boat for leaks. Silicone can be used to seal the rivets. If you have questions, please call your dealer.

How should I store my kayak?

It is best to store your kayak on edge, upside down, standing on end, or hanging on its edges.

Is my boat repairable?

Hobie kayaks are very durable, however, on occasion they may need some minor repairs. Linear polyethylene is repairable. Check with your dealer concerning repairs for your kayak.

Is my boat recyclable?

Hobie will recycle your boat when you are done with it. To recycle a Hobie Kayak, it must be cut up so it fits in a box with the following dimensions: may not exceed 130" length plus girth, and 108" in height. Ship the boat to: Hobie Cat 4925 Oceanside Blvd. Oceanside, CA 92056.

It is our hope that no Hobie Kayak will ever end up in a landfill!



WARRANTY INFORMATION

Hobie provides a two year limited hull warranty.

Your warranty registration card is packaged with this owner's manual and should be completed and returned to Hobie Cat within 30 days of the date of purchase. If you have problems with your boat, contact your dealer first. If you need further assistance, contact Hobie Cat. To help process any warranty problems, please complete your warranty card and give it to your dealer or mail it directly to Hobie Cat.

Hobie warrants each kayak to be free from defects in materials and workmanship for the period listed below. For retail customers in the United States, U.S. possessions and Canada, Hobie will repair or, at its discretion, replace defective parts.

The warranty period for the hull is two years and one year for the Mirage Drive, rudder, seat and paddle.

This warranty does not cover:

- Normal wear and discoloration.
- Damage caused by abuse or failure to perform normal maintenance.
- Damage caused by hitting submerged objects or beaching without retracting or removing the Mirage Drive and rudder (see page 6).
- Mirage Drive Sails are not covered for impact and wear damage.
- Damage caused by mooring or storing boat in water.
- Damage caused by alterations or modifications.
- Transportation of boat or parts to Hobie or its dealers.
- Any boat used as a rental or placed in commercial service.
- Any other consequential damage, incidental damages or incidental expenses, including damage to property. Some states do not allow the exclusion or limitation of incidental or consequential damages, so the above limitation may not apply to you.

To Obtain Warranty Service: Within 30 days of discovering a defect, take your boat, along with the proof of purchase (sales receipt) to the authorized Hobie dealer from whom you purchased your boat, unless you have moved or are traveling. In that case, take it to the nearest authorized Hobie Kayak dealer.

Implied Warranties: Any implied warranties, including implied warranty of merchantability and fitness for a particular purpose, shall be no longer than the duration of this express warranty. Some states do not allow limitations on how long an implied warranty lasts, so the above limitations may not apply to you. Hobie makes no express warranties in addition to this limited warranty. Hobie Dealers have no authority to make warranties on behalf of The Hobie Cat Company in addition to, or inconsistent with, those stated herein.

To the extent any provision of this warranty is prohibited by Federal, State or Municipal law and cannot be preempted, it shall not be applicable. This warranty gives you specific legal rights.



HOBIE CAT

4925 Oceanside Blvd.
Oceanside, CA 92056

Phone (760) 758-9100 Fax (760) 758-1841

www.hobiekayak.com

1. All Hobie Mirage Kayaks are now equipped with the new Mirage Drive Adjuster System. To adjust, squeeze the handle, move the pedal to the desired position and release the handle, making sure the pin drops into the new hole.

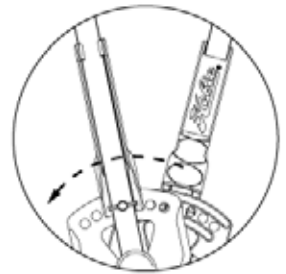
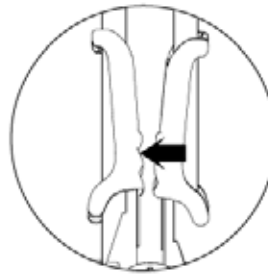

2. Your Hobie Mirage is shipped with a Mirage Cassette Plug. The plug is provided as standard equipment in the Mirage Kayak package and is used to fill the space where the Mirage Drive fits into the hull. It is inserted when the Mirage Drive is removed to provide added safety and to “fair” the hull bottom while paddling.



To Install, simply place the plug in the hole for the Mirage Drive mechanism and lock it down using the cam lock knobs.